



LABEL SYSTEMS



LS 1000 SYSTEM

LS 1000 SYSTEM

BASIC SYSTEM INCLUDES

- LS 75 / 80 mm Label Head
- 19" Sidewrap Assembly
- 2 Meter Conveyor

TECHNICAL DATA

- **Label Heads Available**
LS75 / LS400 / LS450
- **Label Width**
80 mm 120 mm 150 mm 200 mm
(3.15") (4.72") (5.9") (7.87")
- **Product Diameter**
Maximum of 5" Minimum of 1"
- **Conveyor**
Dimensions: Length 6' 6" Width 11"
with speeds up to 100 feet per minute
- **Dispensing Speed**
0-100 feet per minute depending on
type of head used
- **Construction Materials**
Anodized Aluminum and Stainless Steel,
Powder Coated Steel
- **Drives**
AC Fixed Speed (Sidewrap)
DC Variable Speed (Main Conveyor)
- **Sensing**
Fibre Optic Product and Photo Electric
Label Sensor. *Other sensor options
available.*

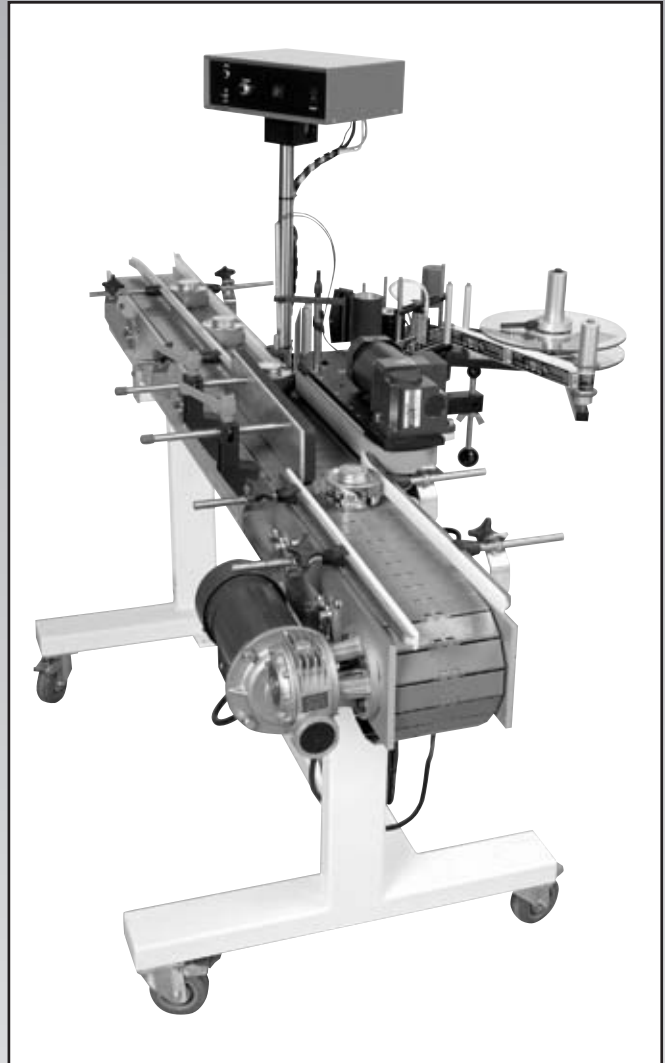

TYPICAL APPLICATIONS

- Side Panel Labelling
- Spot Labelling
- Full Wrap Labelling

OPTIONAL ACCESSORIES

- Hot Stamp Coders
- Programmable Counters



LABEL SYSTEMS

1334 Kerrisdale Blvd., Unit 2
Newmarket, Ontario, Canada L3Y 3V6
Tel: (905) 836-7844 Fax: (905) 853-9357
Web Site: www.label-systems.com

Distributed by: