

LABEL SYSTEMS



LS600

LS600 FROM LABEL SYSTEMS

TECHNICAL DATA

- **Label Width**
80 mm 120 mm 150 mm 200 mm
(3.15") (4.72") (5.9") (7.87")
- **Dispensing Speed**
LS600 – 300 feet per minute
- **Label Peel Tip Accuracy**
LS600 + or -1/32" (0.75 mm)
- **Construction Materials**
Anodized Aluminum and Stainless Steel
- **Drive**
Servo Motor
- **Sensing**
Fibre Optic Product and Label Sensing
Other sensor options available

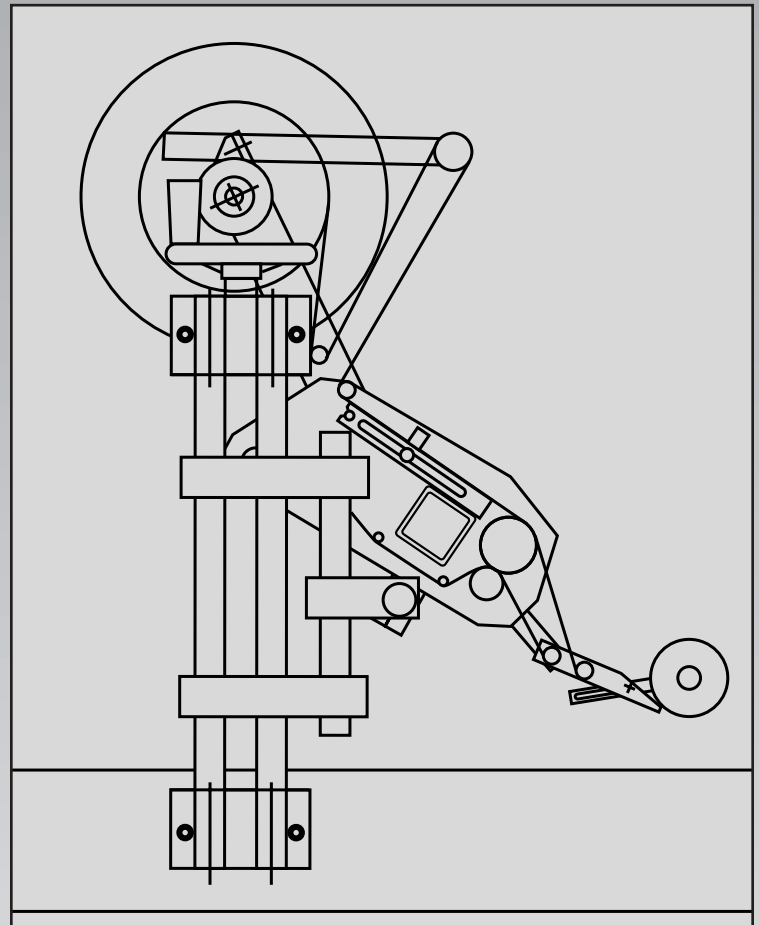

LS600-80 (LH) SERVO MOTOR on Height and Tilt Assembly

TYPICAL APPLICATIONS

- Top Labelling
- Side Panel Labelling
(with one or two applicators)
- Wrap-Around Labelling

BAR CODE PRINTERS

- Stand Alone
- Network

OPTIONAL ACCESSORIES

- Code Printer
- Feed Screws
- Label Coders
- Bar Code Readers
- Missing Label Detectors
- Programmable Counters
- Custom Designed Material Handling Systems



LABEL SYSTEMS

1334 Kerrisdale Blvd., Unit 2
Newmarket, Ontario, Canada L3Y 3V6
Tel: (905) 836-7844 Fax: (905) 853-9357
Web Site: www.label-systems.com

Distributed by:
